

LA-78

Laser alignment aids

en 03-2015/07 601200-02

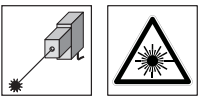

50m

- Red-light laser, Laser class 2
- Sturdy aluminum housing
- Battery-operated
- Suitable for SOLID, COMPACTplus, SLS 78, RS4



Accessories:

- 2x1.5V AAA batteries (built-in)

Dimensioned drawings

Laser Alignment Aid LA-78

Mounting: **SLS 78**

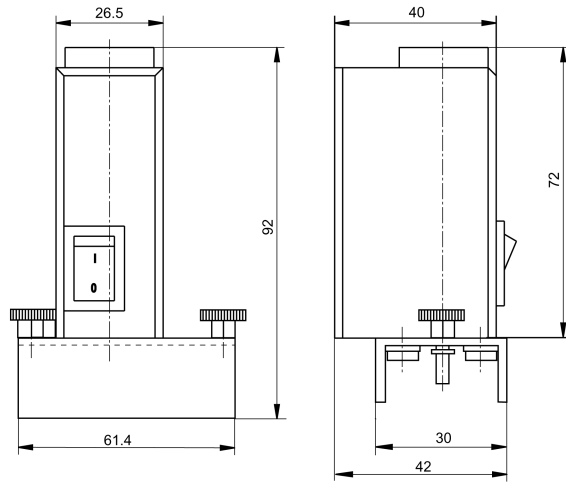

Laser Alignment Aid LA-78U

Mounting: **COMPACTplus**

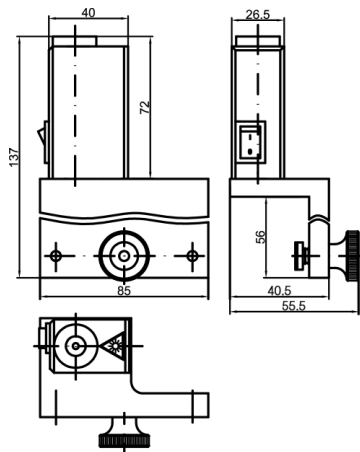

Laser Alignment Aid LA-78U

Mounting: **SOLID**

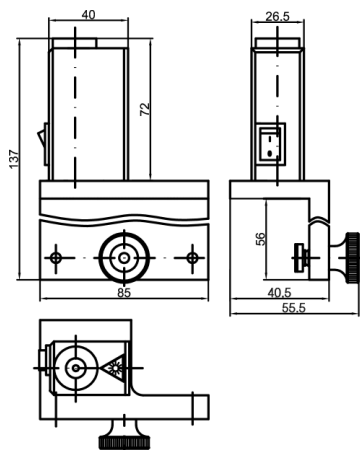

Laser Alignment Aid LA-78UDC

Mounting: **UDC**

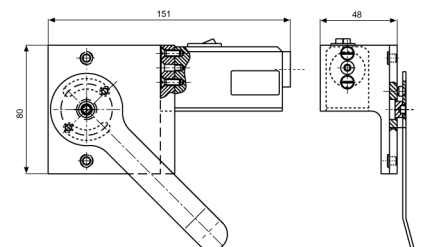

We reserve the right to make changes • DS_LA78_en_601200_02.fm

Specifications

Optical data

Light source	red light laser
Laser class	2 in accordance with IEC 60825-1:2007
Wavelength	650 ... 670nm (visible red light)
Pulse duration	continuous wave (cw)
Maximum output power (peak)	1 mW
Visual range	approx. 50m depending on ambient light

Electrical data

Voltage supply	2 commercially available AAA batteries 2x1.5V replaceable
Ready to operate	approx. 8 hours in permanent operation
Switching on/off	by pressing the flip switch

Mechanical data

Housing	aluminium
---------	-----------

Environmental data

Ambient temp. (operation/storage)	-20°C ... +55°C/-30°C ... +70°C
Protection class	IP 45
Standards applied	IEC 60825-1, 21 CFR 1040.10

Selection Table

For Sensor	Sensor type	Mounting variant ¹⁾ with		
		LA-78	LA-78U	LA-78UDC
SLS78	Single Beam Safety Light Barriers	A	–	–
RS4	Scanner	B	–	–
COMPACTplus	Safety Light Curtain	–	C	D
	Multiple Light Beam Safety Device	–	C	D
	Transceiver, 2-beam	–	C	D
SOLID	Safety Light Curtain	–	C	D

- 1) **A** = Fixing directly on the sensor's threaded bushings
B = Attach on scanner housing
C = Fixing on the guide slot on the side
D = Fixing between mounting column and sensor housing

Remarks

Intended use

Laser alignment aids LA-78... are battery-operated red-light lasers used for the quick and easy adjustment of Leuze electronic optical sensors.

Areas of application

Aligning Laser Scanners, Single Beam Safety Light Barriers, Multiple Light Beam Safety Device, Light Curtains, and deflecting mirrors, especially for multi-sided safeguarding by means of deflecting mirrors and for longer operating ranges.

Operate in accordance with intended use!

- ☞ The product may only be put into operation by competent persons.
- ☞ Only use the product in accordance with the intended use.

Mounting

Type	Application
LA-78	Place against the front of the optics module and attach using knurled-head screws
LA-78U	Observe mounting arrangement, see page 4! Place guide pins laterally into the T-slot in the housing; lock into position by giving the knurled-head screw a ¼ turn (by turning)
LA-78UDC	Insert clamping limb of the LA-78UDC between sensor housing and UDC housing. Place guide pins laterally into the T-slot in the sensor housing; lock into position by swivelling the lever approx. 90°.

Battery change

To change the AAA cells, the two screws M2.5 on the bottom and the cover have to be removed. Change the AAA cells acc. to the figure, mount the cover and fasten the screws.

Order guide

	Designation	Part No.
for Sensors SLS78, RS4	LA-78	549000
for Sensors COMPACTplus, SOLID; Fixing on the guide slot on the side of the sensor	LA-78U	560020
für Sensoren COMPACTplus, SOLID; Fixing between mounting column and sensor housing	LA-78UDC	520004

Laser safety notices



ATTENTION, LASER RADIATION – LASER CLASS 2

Never look directly into the beam!

The device fulfills the EN 60825-1:2008-05 (IEC 60825-1:2007) safety regulations for a product in **laser class 2** as well as the U.S. 21 CFR 1040.10 regulations with deviations corresponding to "Laser Notice No. 50" from June 24th, 2007.

- ↳ Never look directly into the laser beam or in the direction of reflecting laser beams!
If you look into the beam path over a longer time period, there is a risk of injury to the retina.
- ↳ Do not point the laser beam of the device at persons!
- ↳ Intercept the laser beam with an opaque, non-reflective object if the laser beam is accidentally directed towards a person.
- ↳ When mounting and aligning the device, avoid reflections of the laser beam off reflective surfaces!
- ↳ **CAUTION!** Use of controls or adjustments or performance of procedures other than specified herein may result in hazardous light exposure.
- ↳ Adhere to the applicable legal and local regulations regarding protection from laser beams.
- ↳ The device must not be tampered with and must not be changed in any way.
There are no user-serviceable parts inside the device.
Repairs must only be performed by Leuze electronic GmbH + Co. KG.

NOTICE

Affix laser information and warning signs!

Laser information and warning signs are firmly attached to the device (see ①).

①

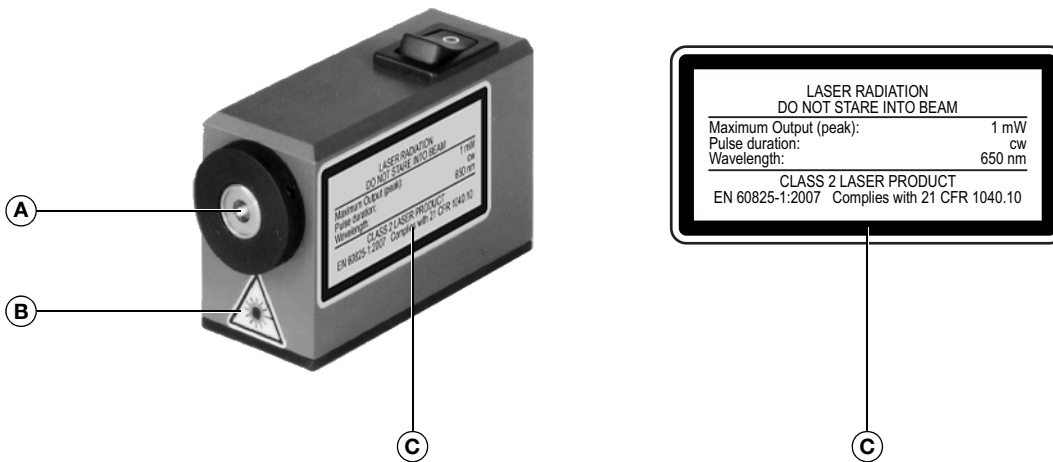

- A** Laser exit opening
- B** Laser warning sign
- C** Laser information sign with laser parameters

Mounting arrangement of LA-78U for COMPACTplus, SOLID

LA-78U: Mounting in hole row C/R for COMPACTplus

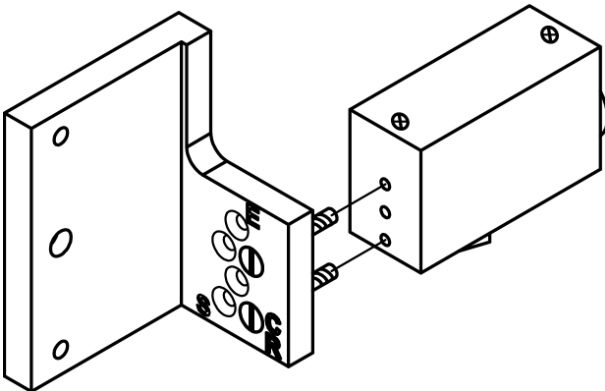

LA-78U: Mounting in hole row S for SOLID

